

# HIFIMAN



FACEBOOK



Scan QR Code to join  
HIFIMAN on facebook

## ISVARNA



HYBRID HEADPHONE



Stealth Magnets  
Design

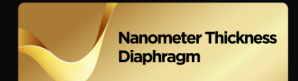

Nanometer Thickness  
Diaphragm



# NATIONAL CENTER FOR THE PERFORMANCE ARTS







## Table of Contents

---

01-02 Message from the Founder

---

03 Enhance low-frequency response

---

04 Study Speakers with both a High - Low-Frequency Crossover

---

05 Phase Differential in Multi-driver Headphones

---

06-08 Hybrid Headphone Technology

---

09-10 Stealth Magnets

---

11-12 Nanometer Thickness Diaphragm

---

13-14 The Headband

---

15-16 Tranquility Pads

---

17-18 Cables

---

19-20 Technical Data

---

21 Headband Adjustment & Replacing Ear Pads

---

22 Care and Maintenance

---

23 HIFIMAN Limited Warranty

---



## Message from the Founder

Thank you for your purchase of a HIFIMAN product. We take great pride in offering audio products that provide best-in-class performance and value.

Though it seems like only yesterday when I started HIFIMAN as a passionate audiophile, we just finished our first decade in business and eagerly look forward to an exciting future. The company has grown rapidly and the HIFIMAN brand has become one of the most respected in the industry.

Even with our success, the one thing that has not changed is my passion for music and creating products that help recreate that live experience. Now, I am joined by many others in the company who share my passion and in turn, we humbly share that with you.

Thank you again for your purchase. I hope you will find this guide useful in learning about your product which will help you enjoy countless hours of listening pleasure.

Happy listening,

*Fang*

Dr. Fang Bian,  
Founder and CEO

## Enhance low-frequency response and enjoy audiophile-grade sonics



SUSVARA

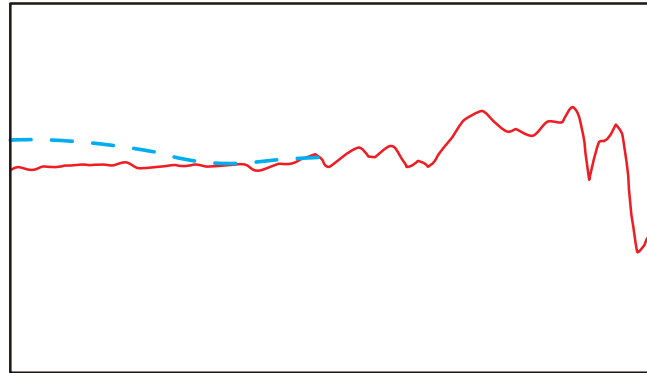

## Study Speakers with both a High - Low-Frequency Crossover

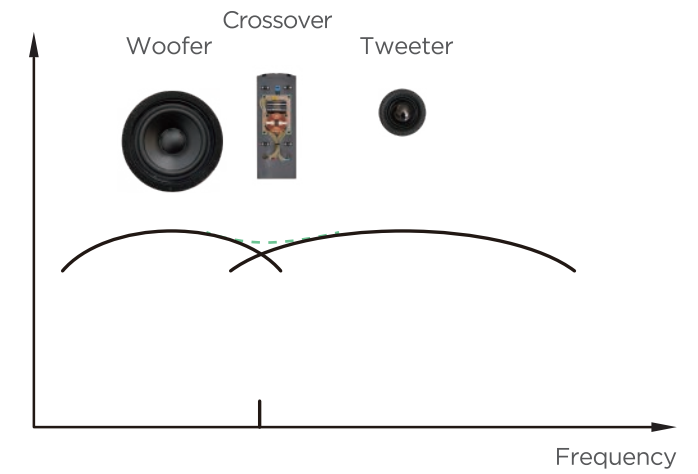

## Phase Differential in Multi-driver Headphones

At a distance, speakers serve as point-specific sound sources, resulting in a small difference in phase, or perceived placement.

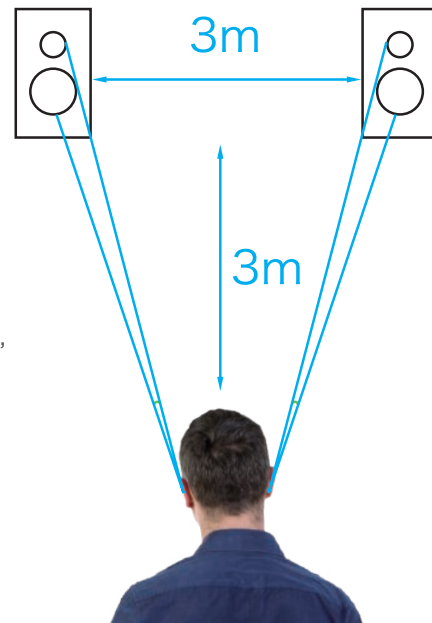

When the distance is limited, the space between the speaker and the ear appears large, resulting in a significant phase difference that degrades sound quality.

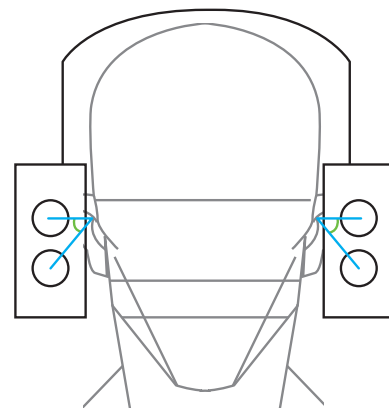

## HIFIMAN solves the problem of phase differential

The angle difference combined with the special installation method for the primary planar driver and a dynamic "subwoofer" effectively solves the phase issue.

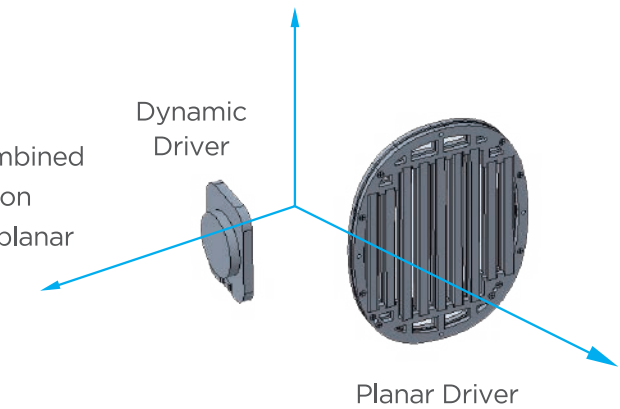

Independently developed dynamic drivers handle low frequencies, while planar drivers are responsible for mid and high frequencies.

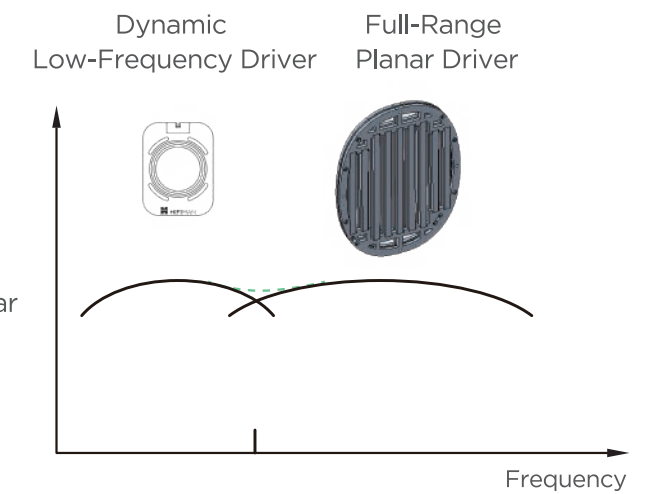

# Oval-shaped Dynamic Driver Subwoofer

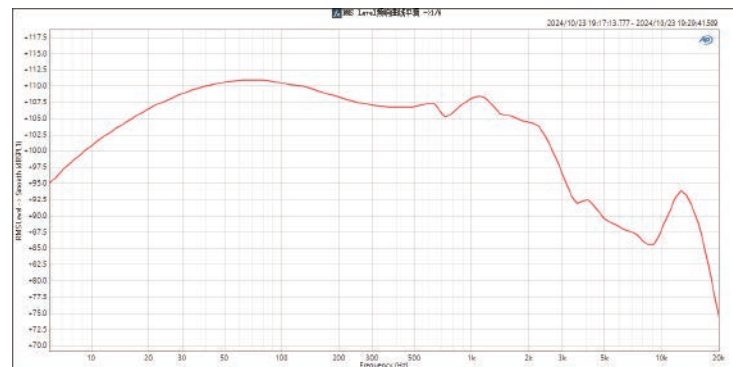
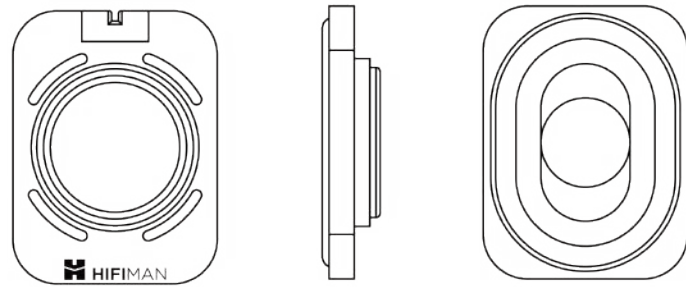

# Crossover Principle and Frequency Response Curve Comparison

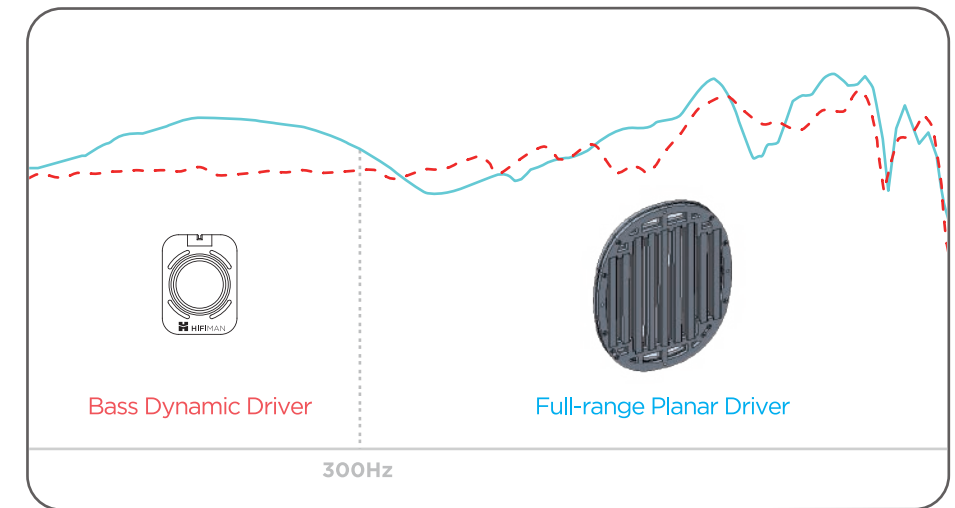

- HIFIMAN ISVARNA Frequency Response Curve
- - - Typical Frequency Response Curve of HIFIMAN Open-Back Planar Headphones



## Stealth Magnets



The streamlined cross-sectional shape of the Stealth Magnets optimizes and reduces the air turbulence and diffraction between the magnets, allowing the sound to pass between them with maximum purity and no disruption to the overall sound quality that is often experienced with traditional magnets.

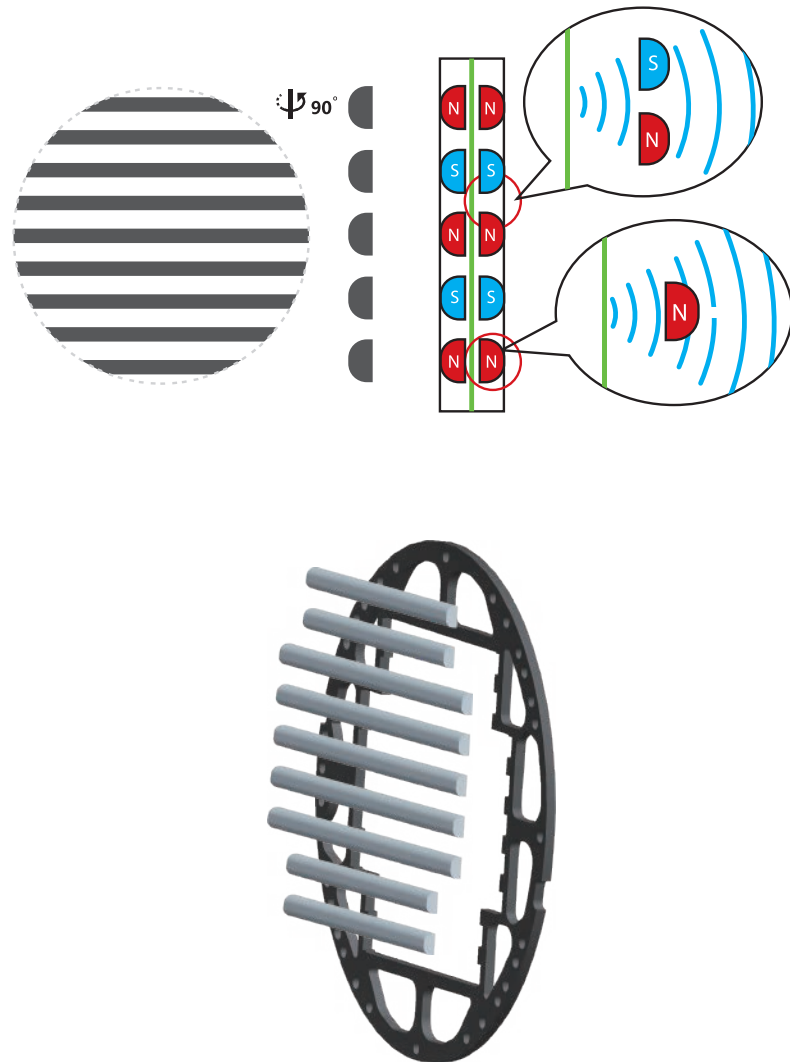



## Nanometer Thickness Diaphragm



The Nanometer Thickness Diaphragm features a mass of just a few micrograms, providing audio playback with ultra-fast response, exceptional dynamic range, precise frequency characteristics, and minimal distortion.



## The Headband

The ISVARNA headband features an advanced ergonomic design, crafted from selected metal materials, precisely cut using high-precision CNC technology and hand-polished by specialists. It seamlessly combines unmatched comfort with exceptional durability.





## Tranquility Pads

The ISVARNA's "Tranquility" ear pads feature high quality leather on the outside, with a ring-shaped inner surface to absorb sound and prevent sound leakage through the sides of the ear pad. This forces the sound to target the listener's ear. The contact edge is constructed of highly permeable material to ensure optimal head comfort.

The outcome of this advanced engineering is a transparent, coherent, and wide soundstage, and maximum comfort.







## Cables

### A range of cables suited for various applications

The ISVARNA package includes three detachable cables:

- one single-ended 1.5m cable with 3.5mm jack, compatible with most portable audio devices, mobile phones, PCs, and more.
- one single-ended 3m cable with 6.35mm jack, ideal for use with professional headphone amplifiers.
- one balanced 3m cable with XLR jack, designed for use with professional headphone amplifiers.

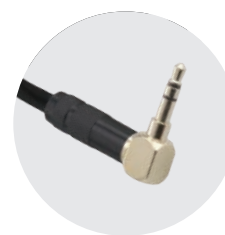

3.5mm (1.5m)



XLR Balanced (3m)



1/4" (6.35mm) (3m)



## Technical Data

### Specifications

Frequency Response: 6Hz-60KHz

Impedance: 16 $\Omega$

Sensitivity: 93dB

Net Weight: 462g

ISVARNA headphone x 1

Four-pin XLR balanced headphone cable (3m) x 1

6.35mm plug headphone cable (3m) x 1

3.5mm plug headphone cable (1.5m) x 1

Ear pads (installed on the headset) x 1 pair

Owner's Guide x 1

## Headband Adjustment

To help fit the headphone to your head, you may use the two adjustment blocks to change the position of the headband strap to better accommodate your head.

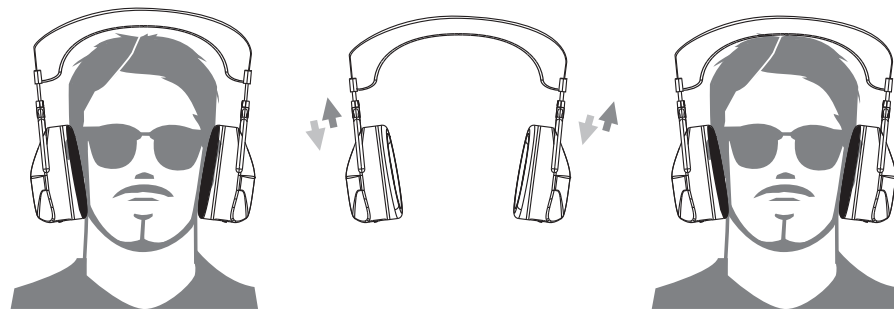

## Replace Ear Pads

The ear pads are designed to be directly attached to the earphones, so if you need to replace the ear pads, please attach them carefully. To remove old pads, directly pull from the edge away from the cup housing. They are attached with Velcro and should peel off easily.

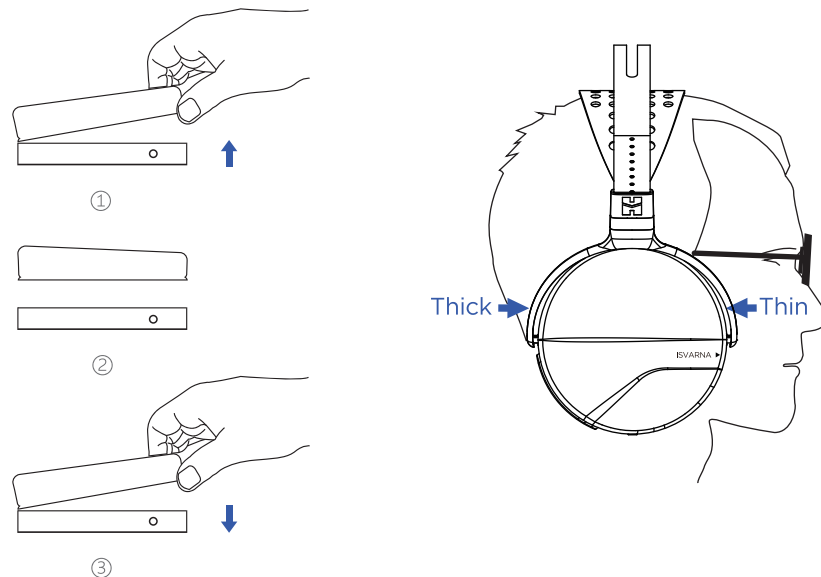

## Care and Maintenance

Planar headphones benefit from break-in to achieve optimum performance. Usually this takes up to 150 hours. There is nothing special you need to do other than enjoy your headphones.

Wipe the surfaces (ear pads, cups) with a microfiber cloth and store the headphone in a dry, cool place, away from dust, heat, humidity, sunlight, young children, and pets.

Do not expose the headphone to excessive heat or cold temperatures.

Do not use any headphone while driving or operating machinery.

Do not use volatile substances to clean the headphone. Alcohol, acetone, gasoline, and dish detergent may harm the headphone.



## HIFIMAN Limited Warranty

ISVARNA is warranted for a period of three years beginning with the original date of purchase. If you join the official HIFIMAN group on Facebook, your product warranty will be extended for an additional six months. Please contact HIFIMAN customer service if you need any assistance.

The dated sales or delivery receipt is your proof of purchase. You may be required to provide proof of purchase as a condition of receiving warranty service so please keep it handy.

If your product is under warranty and malfunctions occur, please contact HIFIMAN customer service or your authorized dealer. If necessary, and at the discretion of HIFIMAN, the company will provide a warranty repair or replacement of your product.

Caution: do not disassemble or modify the product in any way. Tampering with or modifying your HIFIMAN product will void its warranty.

This Limited Warranty does not apply to :

1. Defective or discolored parts if the damages are caused by fluids, dirt, missing keys, broken plastic parts or improper use.
2. Damage caused by misuse with another product.
3. Use of the product for other than its normal intended use, including, without limitation, failure to use the product in accordance with the supplied "Owner's Guide"
4. Damage caused by accident, abuse, neglect or misuse.
5. If you do not have a valid dated receipt showing proof of purchase.
6. Damage caused by services/repairs or other modifications to the system carried out by anyone other than HIFIMAN or an authorized HIFIMAN distributor or dealer.
7. Damage caused by self-repair or if the unit has been disassembled or modified in any way.

HIFIMAN guarantees your satisfaction and will do everything reasonable to achieve that. If you have any questions or concerns with your product, simply contact your authorized dealer or HIFIMAN directly (if purchased from us) and explain the issue in detail. Should a return be required, a RA# will be issued. Return shipping to HIFIMAN or authorized service facility will be at the owner's expense.

The warranty applies to the first purchaser and is not transferable. Should you need warranty service please contact your authorized HIFIMAN dealer. Or email us directly at [customerservice@HIFIMAN.com](mailto:customerservice@HIFIMAN.com)

If you have any concerns with your product: please contact us to explain the issue in detail. If a return/refund is required, a RA# will be issued. Return shipping to HIFIMAN or authorized service facility is done at the owner's expense.

**For any further information or questions, please contact your authorized HIFIMAN dealer. Or email us directly at [customerservice@HIFIMAN.com](mailto:customerservice@HIFIMAN.com).**



HIFIMAN ELECTRONICS CORPORATION  
 Address: 2602 Beltagh Ave, Bellmore, NY 11710, USA